

▶ Die Button Dowel Hole (PDBD)

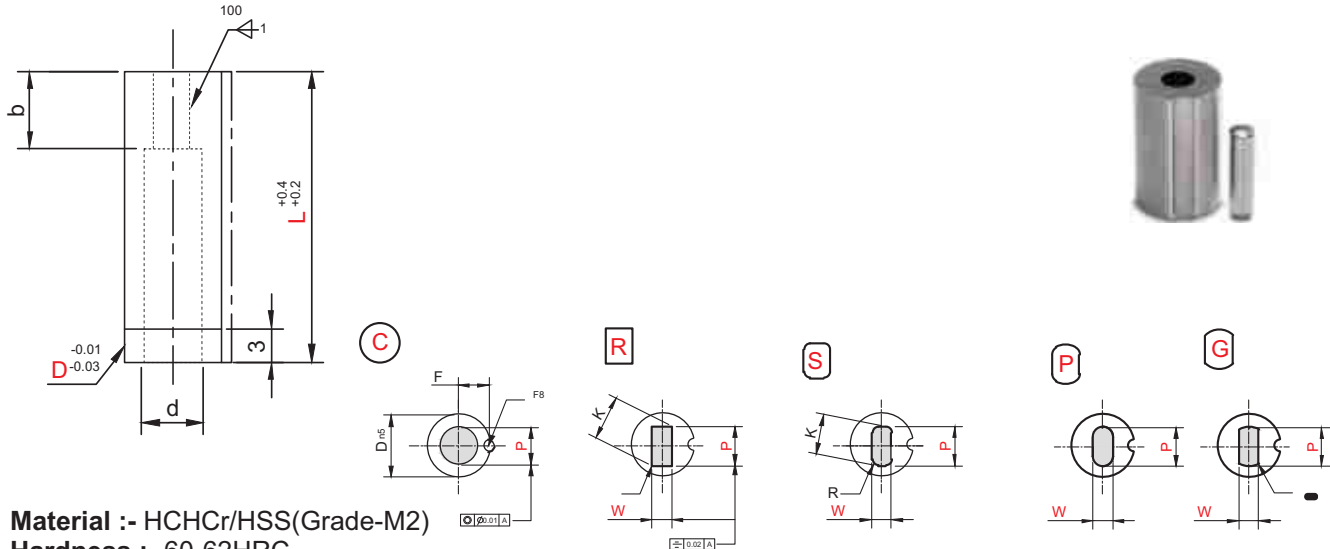

Material :- HCHCr/HSS(Grade-M2)
Hardness :- 60-62HRC

Dm5	Type	D	L	0.01 mm increments				MT (workpiece material thickness)	C (clearance)	b	d	f	
				C	R S P G		R						
				min. P max.	P. K max	P. W min	R						
10	(+0.016) (+0.010)	10	16 20 22 25 28 30 32 35	2.00 -6.00	6	2	0.15 < R < W/2	MT > 0.5	C > 0.06	8	6	6.4	6
13	(+0.020) (+0.012)	13	16 20 22 25 28 30 32 35	3.00 -8.00	8	2					8.4	7.5	
16		16 20 22 25 28 30 32 35	5.00 ~ 10.00	10	2	10.6					8		
20	(+0.024) (+0.015)	20	16 20 22 25 28 30 32 35	7.00 ~ 12.00	12	3					12.6	10	
22		22	16 20 22 25 28 30 32 35	8.00 ~ 14.00	14	3					14.6	11	
25		25	16 20 22 25 28 30 32 35	10.00 ~ 16.00	16	3					16.6	12.5	

Order Type :- Code X Type X D X L X P.W
Example :- PDBD X S X 20 X 35 X 3